

40 X 40X 5 THK  
SPIDER CLAMP

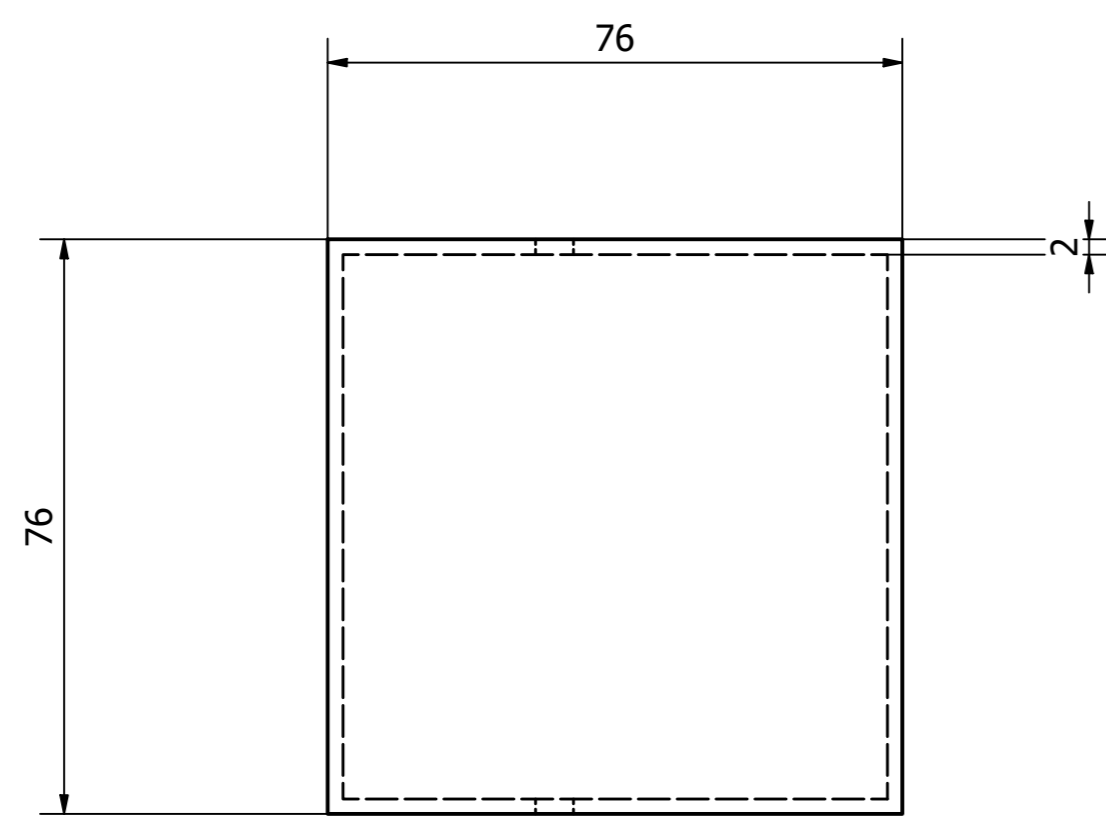

SQ Tubing 76 X 76 X 2 THK

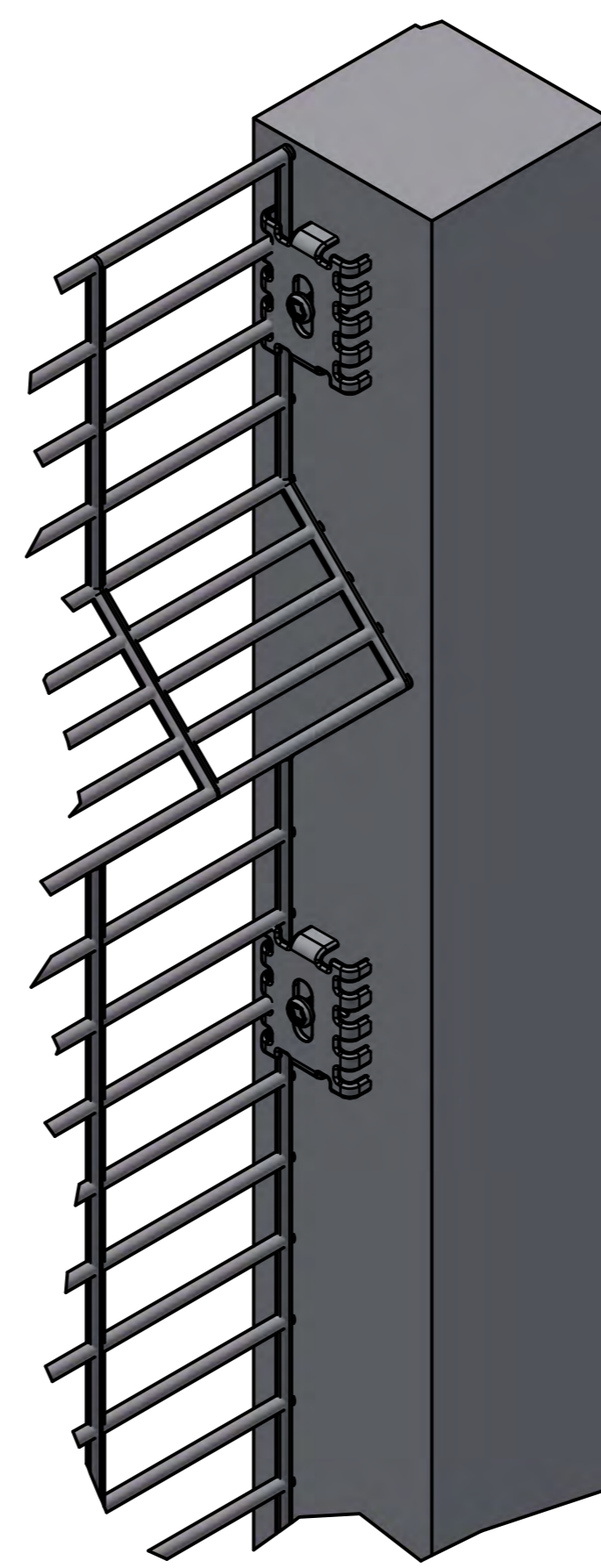

CLAMP DETAIL

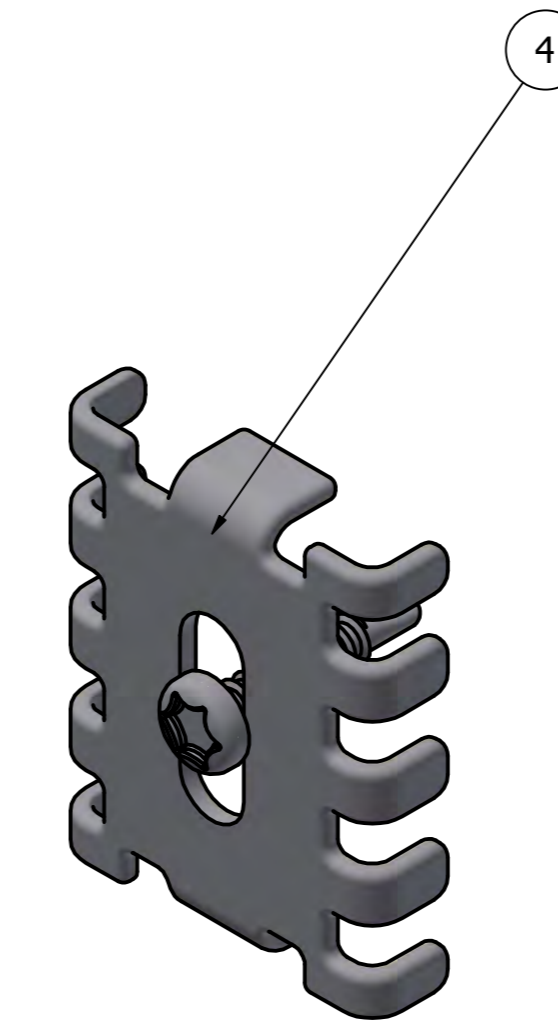

SPIDER CLAMP  
ASSEMBLY

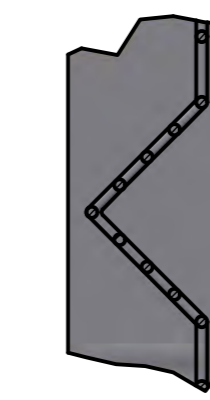

V BEND SIZE

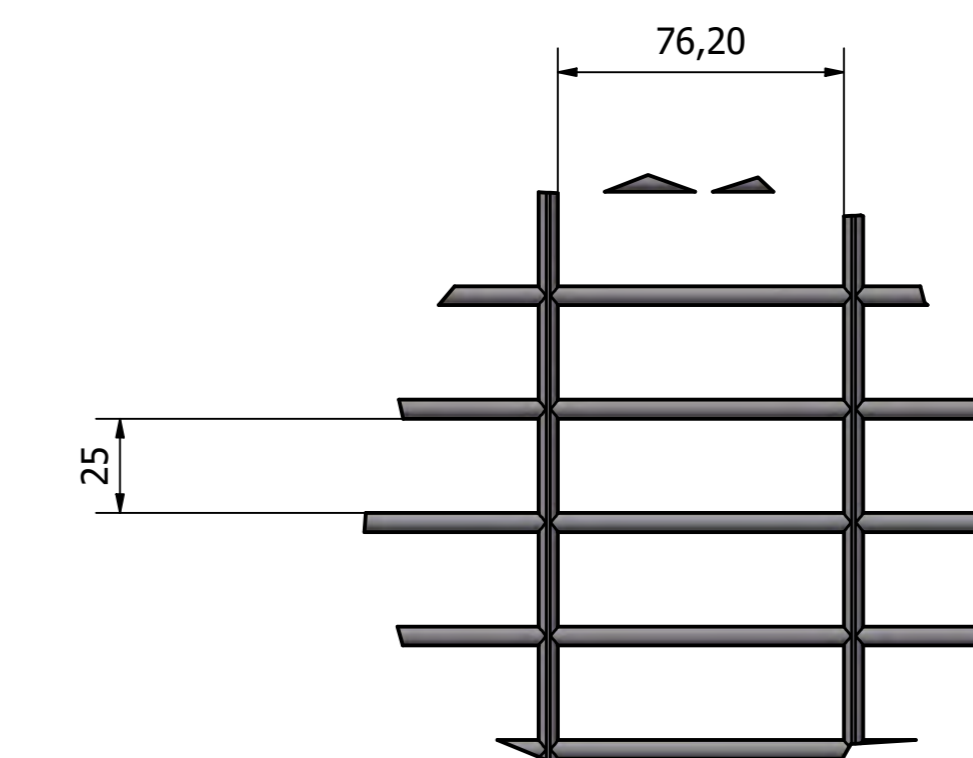

MESH SIZE

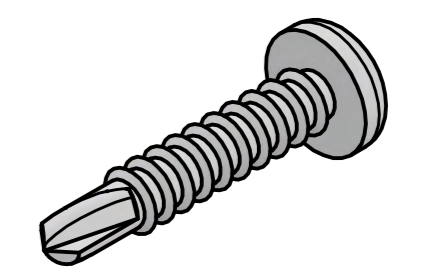
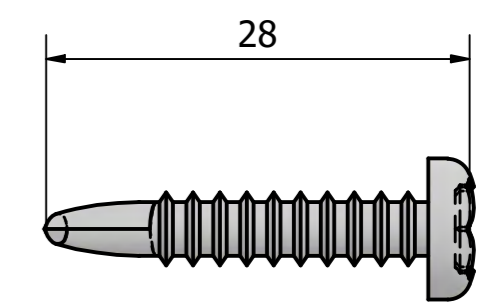
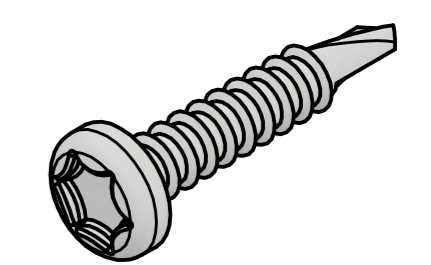

Anodised  
Self Tapping Screw

PARTS LIST			
ITEM	QTY	PART NUMBER	DESCRIPTION
3	1	CONCRETE BLOCK	
4	8	SPIDER CLAM ASSY	
5	38	MESH-PANNEL..	
6	1	76x76x2 Tubing	
7	1	76x76x2 Tubing	
8	1	CONCRETE BLOCK	
9	8	SPIDER CLAM ASSY	
10	1	MESH-PANNEL..	

**MESHTech**<sup>TM</sup>  
SEE-THROUGH FENCING SPECIALISTS  
[WWW.MESHTech.CO.ZA](http://WWW.MESHTech.CO.ZA)

Designed by Jurgens	Checked by Weber	Approved by Weber	Date 3/6/2024	Date 3/6/2024	Sheet 1 / 1
------------------------	---------------------	----------------------	------------------	------------------	----------------

A (1:2)